



PH & ORP ELECTRODES

GENERAL INSTRUCTION MANUAL

The information contained in this manual was current at the time of printing. The most current versions of all Hydro Instruments manuals can be found on our website: www.hydroinstruments.com

Rev. 6/5/2020

pH & ORP Electrodes

General Instruction Manual

Table of Contents

I.	General Information	
	A. Important Operational Information	2
	B. Important Handling Considerations.....	2
	C. Electrode Lifespan.....	2
II.	Installation	
	A. Mounting	2
	B. Wiring.....	3
	C. Installation Inspection	3
III.	Setup	
	A. Compensation.....	6
	B. Alarms	6
IV.	Calibration	
	A. pH Calibration Types.....	6
	B. pH Calibration with Buffer Solution.....	7
	C. pH Calibration with Sample Water	8
V.	Troubleshooting	
	A. General Troubleshooting Guidelines	9
	Appendix A: Performance Monitoring	
	A-I. pH Electrode Offset & Slope	11
	Figures:	
	1. Example Mounting Gland, Quick-Disconnect Cap & Cable Assembly	3
	2. pH Menus for RAH-210 & RPH-250	4
	3. pH Menus for RPH-260 & WQM-100.....	5
	4. ORP Menus for RPH-260 & WQM-100.....	5
	5. pH Performance Offset	11
	6. pH Calibrated Slope	12
	7. pH Live & Saved Values for RAH-210 and RPH-250	13

I. GENERAL INFORMATION

A. Important Operational Information

To increase the life expectancy, accuracy and response of the electrode adhere to the following operational guidelines:

1. Keep the electrode wet. Allowing the electrode to dry out will lead to slow response, erroneous readings and damage.
2. Clean the electrode regularly (See Section V, B for more information).
 - i. Take care when cleaning the electrode. Never use a brush or coarse surface for cleaning.
 - ii. To clean, simply rinse the electrode with water. Blot (do not rub) with a lint-free paper towel to remove excess moisture.
 - iii. Specially formulated cleaning solutions can be used to clean the electrode too.
 - iv. Wiping the glass can produce a static charge which interferes with the electrodes ability to read.

B. Important Handling Considerations

1. The electrode is shipped in a cap containing a solution of pH buffer and potassium chloride. The electrode should only be removed from this solution when it is ready to be installed and used.
NOTE: If the electrode will be subject to infrequent use it should be stored in Storage Solution or in a pH 4 buffer solution if Storage Solution is not available. Do not store the electrode in deionized (DI) water as this will damage the electrode.

C. Electrode Lifespan

Just like any piece of equipment, electrodes need to be replaced from time to time as regular maintenance. As sensors age they become less responsive. The offset and slope are metrics by which to measure the electrodes functionality. Refer to Appendix A in this document for more information.

The manufacturing lot number can be found on the label on the electrode. This information can be used to determine the age of the electrode.

II. INSTALLATION

A. Mounting

1. If applicable, install the necessary hardware to mount the electrode. This may be a separate acrylic pot or a PVC gland that threads into the flow cell assembly.
2. Remove the electrode from its buffer cap and place it into its mounting gland. Secure it into place by gently threading it into the gland, rotating clockwise until it stops.
3. Connect the quick-disconnect cap & cable assembly to the top of the pH or ORP electrode by gently threading the cap on, rotating clockwise until it stops.

B. Wiring

Instrumentation ordered with an electrode will have its connection pre-wired and the electrode only

needs to be connected to its quick-disconnect cap & cable assembly after mounting. If an electrode is being added to an instrument that was ordered without one or if the cable assembly is being replaced, please reference the below installation points.

NOTE: If installing an electrode into instrumentation that did not come with one it may be necessary to add an additional liquid tight cable grip into the controller enclosure. This hardware will have been provided with the pH or ORP electrode.

WARNING! Electrical hazards are involved with this installation. Only Qualified personnel should perform this installation.

1. With the instrumentation powered off, run the cable portion the electrodes quick-disconnect cap & cable assembly through the appropriately sized liquid tight cable grip in the controller's enclosure.
2. Consult your instruments Operation & Maintenance manual for the appropriate circuit board diagram illustrating where the pH or ORP electrode should be connected. If you do not have this information please consult Hydro Instruments for assistance.

Figure 1 – Mounting Gland, Quick-Disconnect Cap & Cable



C. Installation Inspection

Reference the Troubleshooting table in this document or the instruments Operation & Maintenance manual if needed.

- ✓ Make sure that the sensing glass is fully submerged.
- ✓ Ensure that the sensing glass is free of air bubbles.
- ✓ There should be a reading on the instrument display.

Figure 2 – pH Menus for RAH-210 & RPH-250

pH Setup

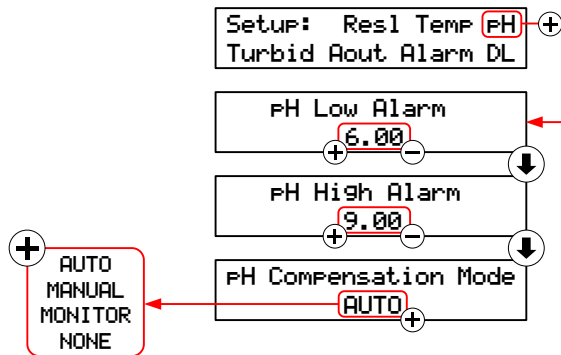

pH Calibration – Buffers

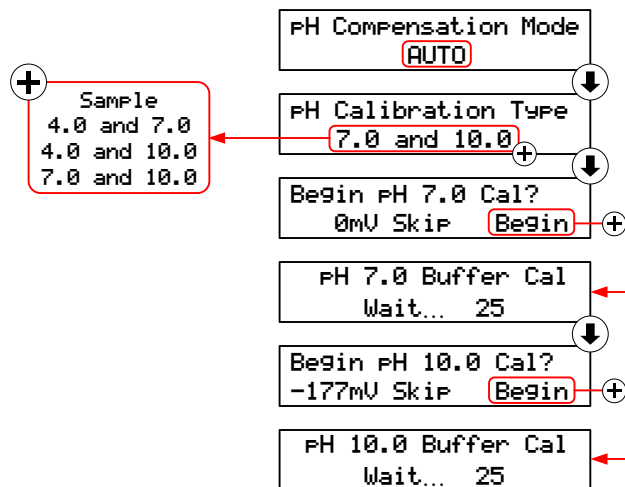

pH Calibration – Sample

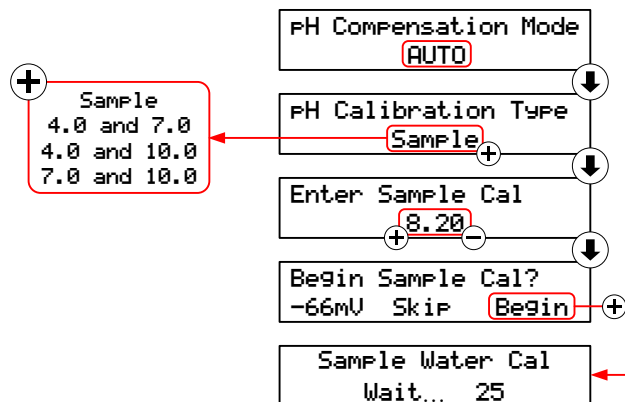

Figure 3 – pH Menus for RPH-260 & WQM-100

pH Setup & Calibration

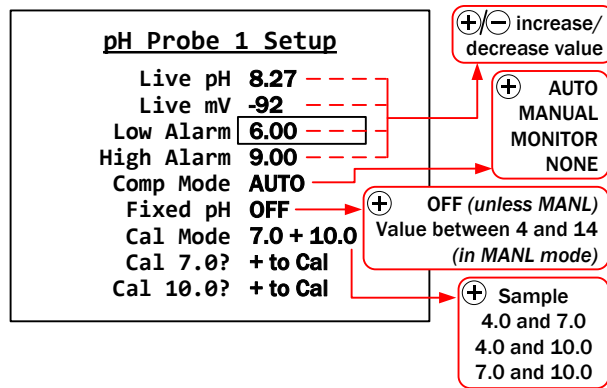
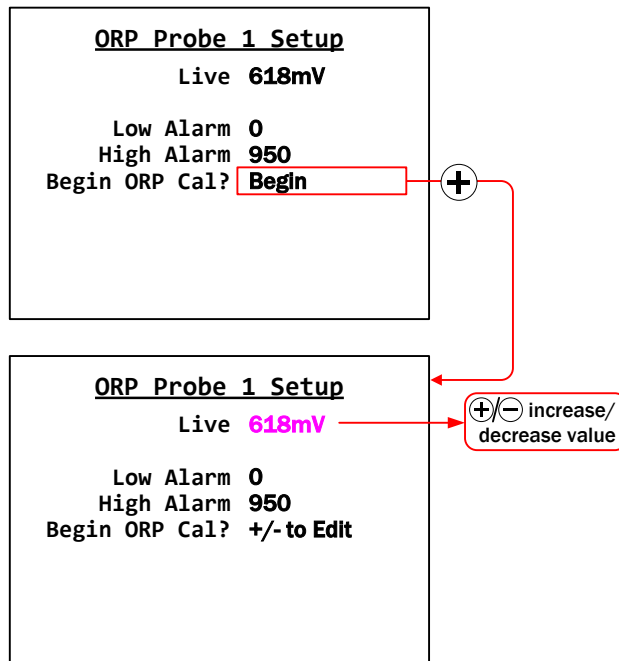

Figure 4 – ORP Menus for RPH-260 & WQM-100

ORP Setup & Calibration



III. SETUP

A. pH Compensation Mode

In the residual analyzers setup menu, choose the pH compensation mode to be used (Reference Figure 2 or 3).

None – The residual chlorine analyzer will assume that the pH of the sample water is stable or has been buffered to a pH low enough such that dissociation is not a concern.

NOTE: When using this compensation mode the pH value will not be displayed on the main operations screen. This compensation mode is generally reserved for instruments that are not using a pH electrode.

Automatic “Auto” – In this mode, the pH of the sample water is measured using the pH electrode and compensation is performed automatically by the controller software.

Manual – The pH of the sample water can be entered and will remain a fixed value unless changed.

Monitor – The pH of the sample water is measured using the pH electrode, but will not be used to compensate for dissociation.

B. Alarms

The residual analyzer has an adjustable low pH alarm setting and an adjustable high pH alarm setting.

pH Low Alarm – Should the sample water pH fall below this value the controller will indicate an alarm status of “Low pH”.

pH High Alarm – Should the sample water pH go above this value the controller will indicate an alarm status of “High pH”.

IV. CALIBRATION

A. pH Calibration Type

Hydro Instruments residual analyzers allow the operator to select from four (4) different pH calibration types (Reference Figure 2 or 3). These options are:

- i. 4.0 and 7.0 – two point calibration using pH 4.0 and 7.0 buffers
- ii. 4.0 and 10.0 – two point calibration using pH 4.0 and 10.0 buffers
- iii. 7.0 and 10.0 – two point calibration using pH 7.0 and 10.0 buffers
- iv. Sample – single point calibration using the sample water

The calibration type to use is up to the operator. However, Hydro Instruments recommends the following:

- If pH buffers are not available, use the ‘Sample’ calibration. This is a single point calibration and will automatically calculate an ideal calibration slope. This provides reasonable accuracy if the sample water is close to pH 7.0 and the pH of the process is relatively stable.
- If the sample water pH is less than 7.0, use the ‘4.0 and 7.0’ calibration.
- If the sample water pH is greater than 7.0, use the ‘7.0 and 10.0’ calibration.

- If the sample water pH is subject to wide swings in pH, use the '4.0 and 10.0' calibration.

B. pH Calibration With Buffer Solution

Quick notes to increase calibration accuracy:

- If the pH electrode is wet, blot the bottom of the electrode with a clean, lint-free paper towel before placing it into the pH buffer solution for calibration.
- Allow the pH electrode to sit in the buffer solution for several seconds prior to calibration (15-30 seconds). The longer it's allow to sit in the buffer solution the closer the reading will be to the ideal value.

NOTE: When calibrating the pH electrode the instrument controller software will count down from 25 seconds to ensure a good calibration.

- Keep the pH electrode and buffer solution stable during calibration. Vigorous movement of the electrode can disrupt the reading and lead to inaccurate calibrations.

NOTE: Should the pH electrode reading be disrupted during calibration the countdown will restart.

- Select a two-point pH calibration range that will be similar to your operating conditions. For example, if the operating range is pH 7.8 to 8.1 than perform a pH "7.0 and 10.0" calibration.
- When calibrating the electrode, always use a fresh pH buffer solution. Buffer should be discarded after use. Never put used pH buffer back into its original storage container as this will contaminate it.
- Use enough pH buffer solution to properly submerge the electrode.
- Be aware of the temperature of the pH buffers being used. Manufacturers will include on their label at what temperature the solution will be at its true pH value. Temperature can influence dissociation and thus if the calibration is done with a pH buffer not at its prescribed temperature, the calibration will be inaccurate.
- pH measurement is temperature compensated. If the sample water and pH buffer have inordinately different temperatures than it may be necessary to temporarily place the instrument into a 'manual' temperature compensation mode and manually input a temperature close to that of the pH buffer for the pH calibration process.
- Air bubbles, oils and other contaminants can form on the pH glass and affect accuracy. Be sure to remove contaminants and air bubbles before calibration.

To calibrate the pH electrode using pH buffers follow these instructions and reference Figure 2 or 3 in this document as well as the instruments Operation & Maintenance Manual if needed.

1. Enter the instruments setup.
2. Navigate to the pH setup & calibration menus.
3. Choose the pH calibration type (e.g. "7.0 and 10.0"). See Section IV, A for additional information.
4. Prepare the first pH buffer solution (e.g. 7.0) in a clean glass beaker or suitable pH neutral vessel.

NOTE: Do not place the pH probe directly into the pH buffer container as this may contaminate the pH buffer solution.

5. If the pH electrode is wet, blot the bottom of the electrode with a clean, lint-free paper towel before placing it into the pH buffer solution for calibration.
6. Place the pH electrode into the pH buffer solution. If the instrument shows a live mV output on the display, allow the mV output to stabilize. If the instrument does not have a live mV output on the display, allow approximately 15-30 seconds to pass before moving on. This will allow the pH electrodes reading some time to stabilize.
7. Begin the first calibration point. A 25 second countdown will start; at the end of which the controller will accept or reject the calibration point.
NOTE: The pH value and mV output will not be displayed during this countdown.
 - i. If the calibration point is accepted, move onto the next step.
 - ii. If the calibration point is rejected, the entire procedure will need to be repeated. If the issue persists, see the troubleshooting section in this document.
8. Prepare the second pH buffer solution (e.g. 10.0) in a clean glass beaker or suitable pH neutral vessel.
NOTE: Do not place the pH probe directly into the pH buffer container as this may contaminate the pH buffer solution.
9. Blot the bottom of the electrode with a clean, lint-free paper towel before placing it into the pH buffer solution for calibration.
10. Place the pH electrode into the pH buffer solution. If the instrument shows a live mV output on the display, allow the mV output to stabilize. If the instrument does not have a live mV output on the display, allow approximately 15-30 seconds to pass before moving on. This will allow the pH electrodes reading some time to stabilize.
11. Begin the second calibration point. A 25 second countdown will start; at the end of which the controller will accept or reject the calibration point.
NOTE: The pH value and mV output will not be displayed during this countdown.
 - i. If the calibration point is accepted the calibration is complete.
 - ii. If the calibration point is rejected, the entire procedure will need to be repeated. If the issue persists, see the troubleshooting section in this document.

C. pH Calibration With Sample Water

Quick notes to increase calibration accuracy:

- Air bubbles, oils and other contaminants can form on the pH glass and affect accuracy. Be sure to remove contaminants and air bubbles before calibration.

To perform a single point calibration using the sample water, follow these instructions and reference Figure 2 or 3 in this document as well as the instruments Operation & Maintenance Manual if needed.

1. Determine the pH of the sample water using a handheld pH meter or other pH measurement instrument.
2. Enter the instrument setup.
3. Navigate to the pH setup & calibration menus.
4. Choose the pH calibration type "Sample". See Section IV, A for additional information.
5. Input the pH value of the sample water as determined in step 1.

6. Begin the 'Sample' calibration. A 25 second countdown will start; at the end of which the controller will accept or reject the calibration point.

NOTE: The pH value and mV output will not be displayed during this countdown.

- i. If the calibration point is accepted the calibration is complete.
- ii. If the calibration point is rejected, the entire procedure will need to be repeated. If the issue persists, see the troubleshooting section in this document.

D. ORP Calibration Type

Hydro Instruments instrumentation utilizing an ORP electrode will use a single point calibration for ORP measurement. (Reference Figure 4)

- i. ORP Cal. – single point calibration using an ORP solution standard

E. ORP Calibration Using ORP Solution Standard

Quick notes to increase calibration accuracy:

- Air bubbles, oils and other contaminants can form on the ORP glass and affect accuracy. Be sure to remove contaminants and air bubbles before calibration.

To perform the single point calibration using an ORP solution standard, follow these instructions and reference Figure 4 in this document as well as the instruments Operation & Maintenance Manual if needed.

1. Enter the instruments setup.
2. Navigate to the ORP setup & calibration screen.
3. If the ORP electrode is wet, blot the bottom of the electrode with a clean, lint-free paper towel before placing it into the ORP solution standard for calibration.
4. Place the ORP electrode into the ORP solution standard. The instrument shows a live mV output on the display, allow the mV output to stabilize. Allow approximately 25-30 seconds to pass before moving on. This will allow the ORP electrodes reading some time to stabilize.
5. Begin the ORP calibration.

NOTE: The live ORP value on the display is what will now be adjusted to match the ORP solution standard.

- i. Adjust the live ORP reading to match the mV value of the ORP solution standard.

V. TROUBLESHOOTING

A. General Troubleshooting

If at any time the pH or ORP electrode is not reading accurately or fails to calibrate, refer to this section of the manual to understand possible causes and their resolutions.

B. Electrode Cleaning

Coatings on the electrodes surface will result in erroneous readings and calibration and may even mimic the effects of a failing electrode. Regular cleaning of the electrode can help prevent this and prolong its lifespan.

CAUTION: Use all recommended precautions when using chemicals of any kind, including protective eyewear, gloves, face shields, etc.

The type of coating will determine the appropriate cleaning method.

Soft Coatings – These can be removed by vigorous stirring of the electrode in clean water or by gently wiping with a soft, clean, non-abrasive cloth.

NOTE: Do not use a brush or abrasive cleaner to clean the glass as this will result in damage.

Hard Coatings – These types of coatings can be removed chemically. Clean the pH electrode using specially formulated solutions ideal to the application. For example, accumulation of calcium carbonate can be removed with a weak (e.g. 5%) muriatic acid.

Oily Coatings – These types of coatings are best removed with detergents or solvents that will not harm the electrode. For example, isopropyl alcohol can be used, but not acetone as the acetone will chemically dissolve plastic.

Organic Coatings – These types of coatings are best removed with detergents or solvents that will not harm the pH electrode. For example, isopropyl alcohol or bleach can be used, but not acetone as the acetone will chemically dissolve plastic.

Protein-based Coatings – These are best removed with an enzyme-based cleaner.

APPENDIX A: PERFORMANCE MONITORING

Guidelines for use and preventative maintenance:

1. Clean regularly (See Section V, B for more information)
2. Calibrate often (See Section IV for more information)
3. Keep the electrode properly submerged at all times.

SECTION A-I: pH ELECTRODE OFFSET & SLOPE

Calibration slope and offset are important to consider as this information provides insight to the pH electrodes overall condition.

pH Electrode Offset

Offset is simply the mV reading deviation from ideal while in pH 7 buffer. Ideally the pH electrode reading would be 0mV in pH 7 buffers, but in reality is rarely ever the case. The offset will change as the pH electrode ages. Should the offset of the pH electrode become too great, this could mean that the pH electrode is dirty and requires cleaning, may be damaged or has expired and needs to be replaced.

Hydro Instruments recommends that the pH electrode offset not exceed $\pm 25\text{mV}$.

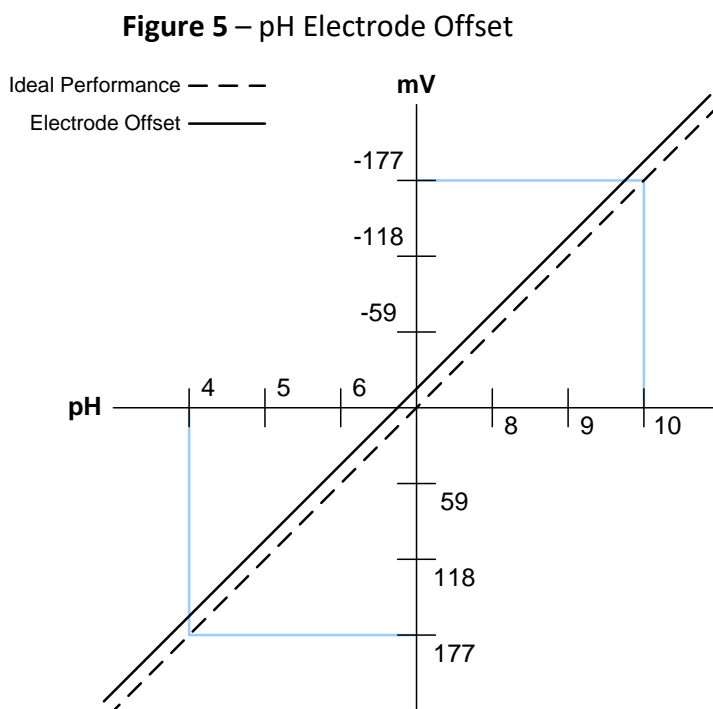

pH Electrode Slope

Slope is the mV change per pH unit. Ideally the slope of the line should be 59mV for every whole pH unit change. If the slope of the pH electrode is too great, this could mean that the buffers used for calibration are not at their correct temperature, expired or possibly contaminated.

Hydro Instruments recommends that the pH electrode slope percentage stay within 85 – 105%.

Figure 6 – pH Electrode Slope

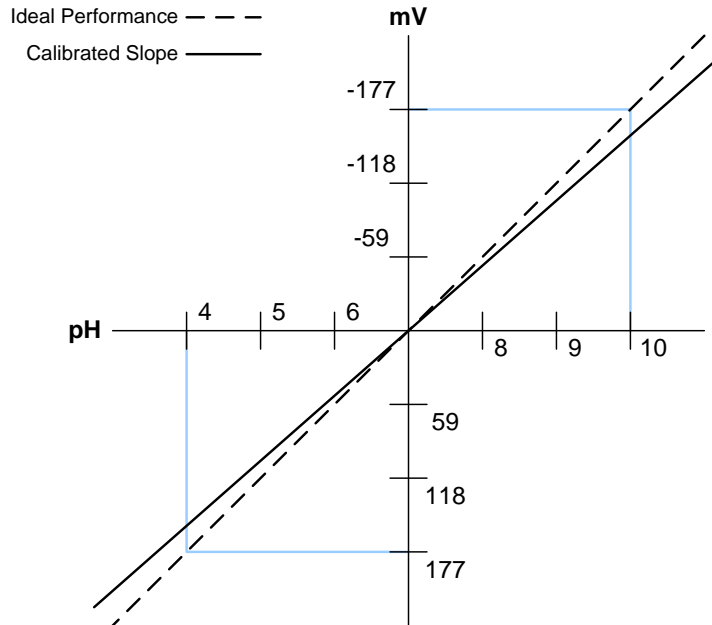

pH Electrode Live & Saved Values for RAH-210 and RPH-250

The pH electrodes slope & offset can be checked on the Hydro Instruments RAH-210 and RPH-250 residual chlorine analyzers by navigating to the hidden pH values screens. Live pH electrode mV, calibrated values, Offset and Slope can be viewed in these screens; reference Figure 7 in this document as well as the instruments Operation & Maintenance Manual if needed.

pH Filter – The live pH readings will be averaged together over this period of time (seconds).

- Increasing the filter will help calm small fluctuations and/or brief spikes in the pH electrodes signal.
- Decreasing the filter will allow for rapid response to changes in pH, but will result in a less stable signal.

```
Resl Filter= 30 secs
pH Filter= 60 secs
```

pH Live – The live pH reading and the mV signal are shown.

```
pH 7.50 7.00 10.00
mV -29 0 -177
```

pH Calibration – The saved pH calibration points are shown. This information can be used to determine that the pH electrode has been correctly calibrated.

```

pH  7.50  7.00  10.00
mV  -29   0    -177
    
```

pH TC – This is temperature (Kelvin) at which the pH electrode was calibrated. This information can be used to determine that the calibration is accurate.

```

pH TC=291.6 s=-59.0
Offset 7pH=0mV
    
```

Slope – The calibrated slope is shown. This value represents the per pH unit range (mV).

```

pH TC=291.6 s=-59.0
Offset 7pH=0mV
    
```

Offset – The offset from 7 pH is shown (mV). This information can determine the condition of the pH electrode.

```

pH TC=291.6 s=-59.0
Offset 7pH=0mV
    
```

Figure 7 – pH Live & Saved Values for RAH-210 and RPH-250

